



* Reference photo

Body and Cover Cast Steel
ASTM A216 WCB

Steel Valves:
ANSI/ASME B16.34

Strainer: Stainless Steel 304 (Opt. 316)

Mesh: 40

Threaded End NPT ANSI B1.20.1

Working pressure and temperature:
800 PSIG at 38°C
250 PSI SWP

Hidrostatic Test API 598

MATERIALS

	PART NAME	MATERIAL
1	PLUG	ASTM A216 WCB
2	COVER	ASTM A216 WCB
3	GASKET	F316 + Graphoil
4	STRAINER	AISI 304
5	BODY	ASTM A216 WCB

DIMENSIONS (mm)

SIZE	A	B	C	WEIGHT (Kg)
1/2"	90	60	105	0.8
3/4"	110	75	140	1
1"	130	93	155	2
1 1/4"	160	120	195	4.5
1 1/2"	160	120	195	4.9
2"	160	145	205	5.9
2 1/2"	300	230	-	13.9
3"	300	230	-	14.97

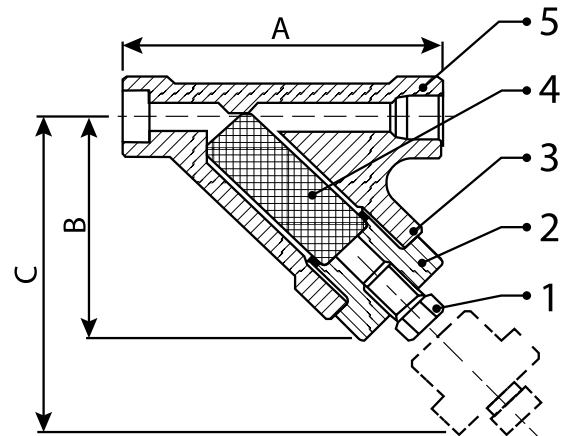

* Note : Dimensions, design and materials are subject to change without notice. Approximate weights.